

MINIMUM GAUGE AND THICKNESS FOR STEEL CASING CONDUIT SYSTEMS		
CASING TYPE	CASING DIAMETER	MIN. WALL THICKNESS
BLACK STEEL	UP THROUGH 26"	0.1345" (10 GAUGE)
SMOOTH WALL	27" THROUGH 36"	0.1943" (6 GAUGE)
	37" THROUGH 42"	0.2242" (4 GAUGE)

The above thicknesses will support a highway loading H-20, or equivalent, with a minimum of 2' burial and 95% of maximum density compacted backfill in cohesive soils or 70% of relative density compacted backfill for cohesive soils. For special loadings and soil conditions, conduit thickness may change.

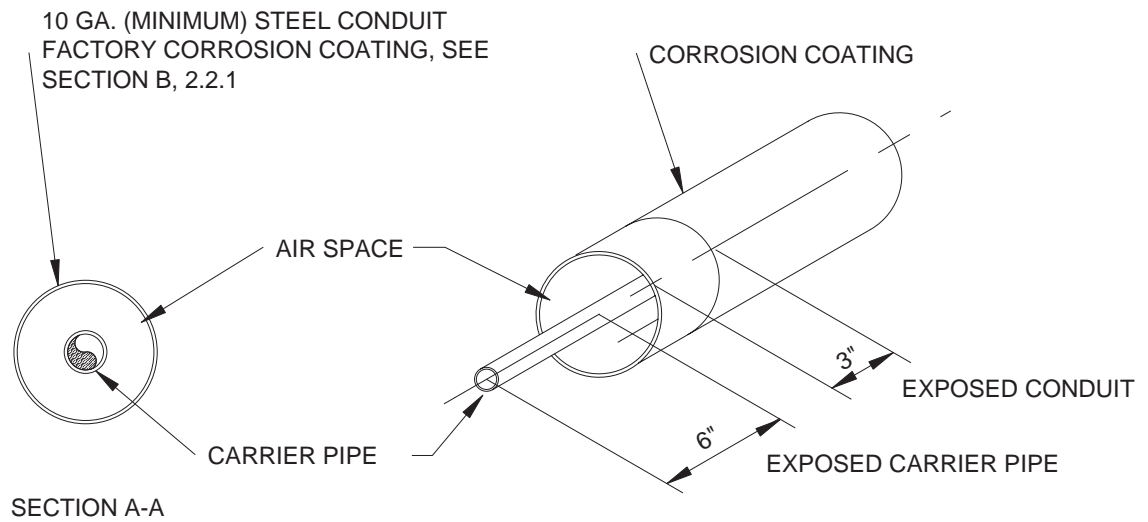

NOTE:

This detail shows a single pipe in a conduit. The support spacing dimensions and casing thickness are applicable for a dual pipe system in a single conduit.

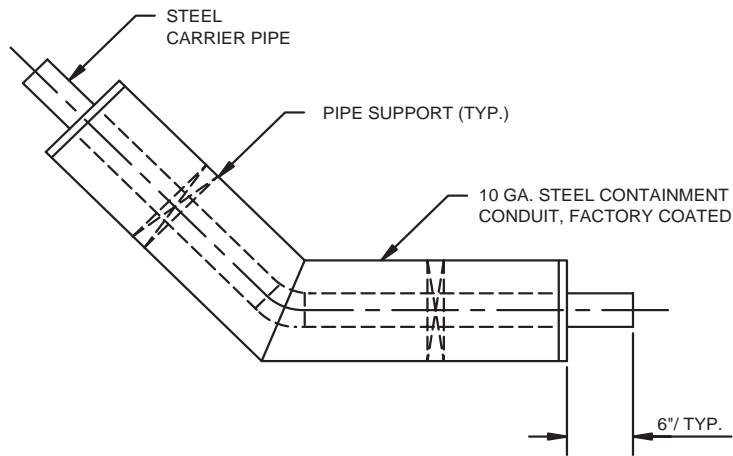

45° ELBOW FITTING DETAIL

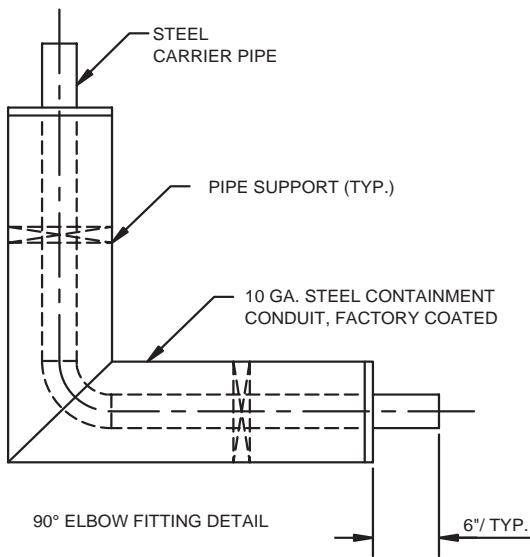

90° ELBOW FITTING DETAIL

PIPE SIZE	CONTAINMENT CONDUIT SIZE
3"	6"
4"	8"
6"	10"
8"	12"
10"	14"

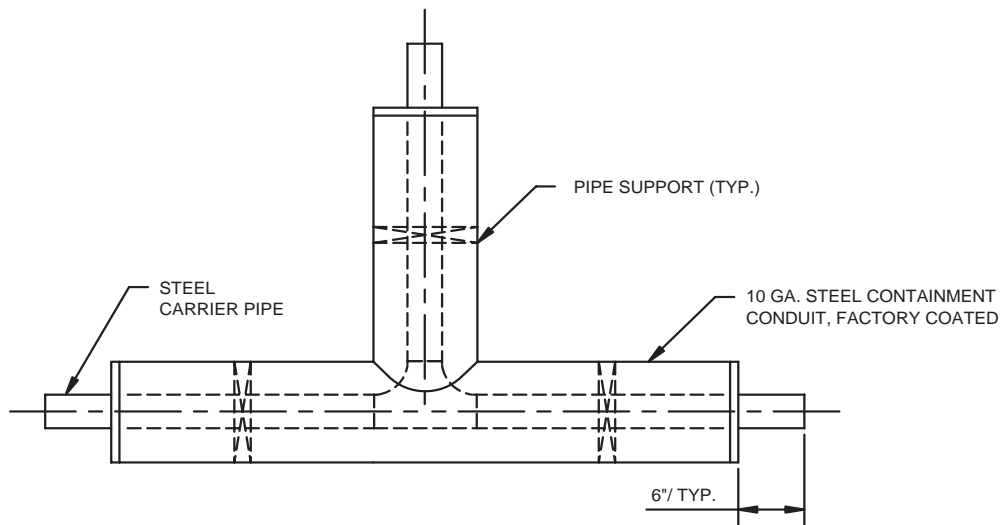

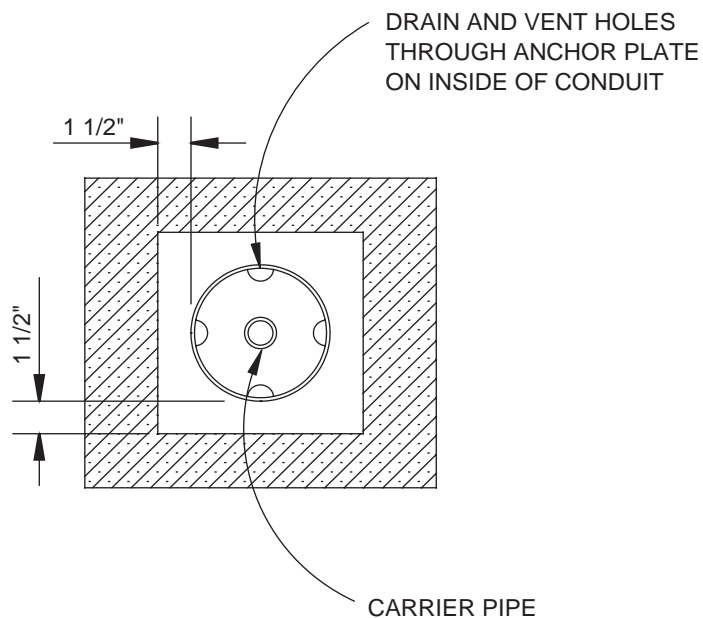
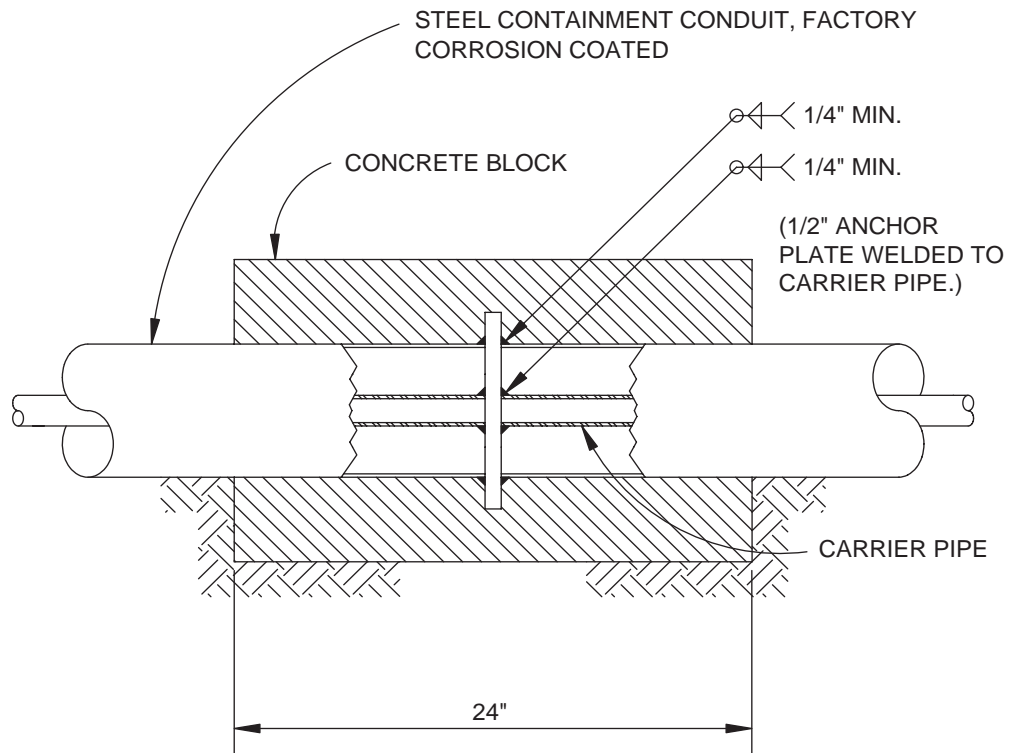

ANCHOR PLATES ARE 1/2" STEEL CENTERED ON CONDUIT WITH DIMENSIONS 1 1/2" LARGER HORIZONTALLY AND 1 1/2" LARGER VERTICALLY THAN NOMINAL CONDUIT DIAMETER. CONCRETE ANCHOR BLOCK EXTENDS MINIMUM OF 12" OUTSIDE ANCHOR PLATE AND IS MINIMUM OF 24" IN LENGTH.

OPTIONAL VENT
LOCATION

1" HALF COUPLING
(VENT)

DRESSER GASKETS
FOR GLAND SEAL

OPTIONAL DRAIN
LOCATION

1" HALF COUPLING
(DRAIN)

**STUD AND NUT TABLE
FOR VARYING PIPE SIZES**

CARRIER PIPE SIZE	NO. OF STUDS AND NUTS
1/2" TO 2"	2
2-1/2" TO 4"	3
5" TO 6"	4
8"	5
10" TO 12"	6
14"	8
16"	10

1" HALF COUPLING (VENT)

GLAND
GLAND FOLLOWER

STAINLESS STEEL STUDS
W/ STAINLESS STEEL NUTS

DRESSER GASKETS
FOR GLAND SEAL

SEAL WALL PENETRATION
W/ 3 COATS OF BITUMUS
MASTIC OR ONE COAT OF
CHEMICALLY BONDED
URETHANE

1" HALF COUPLING
(DRAIN)

10 GAUGE
LEAK PLATE

OAKUM

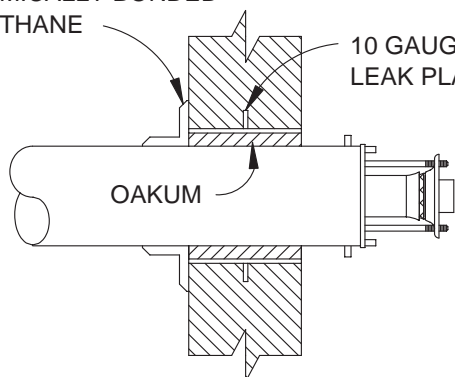

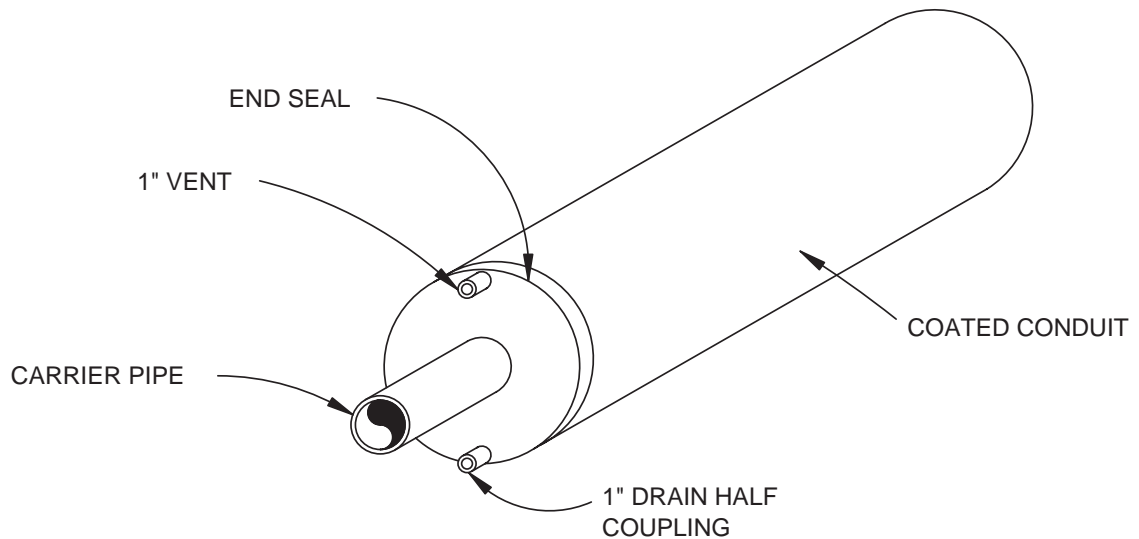
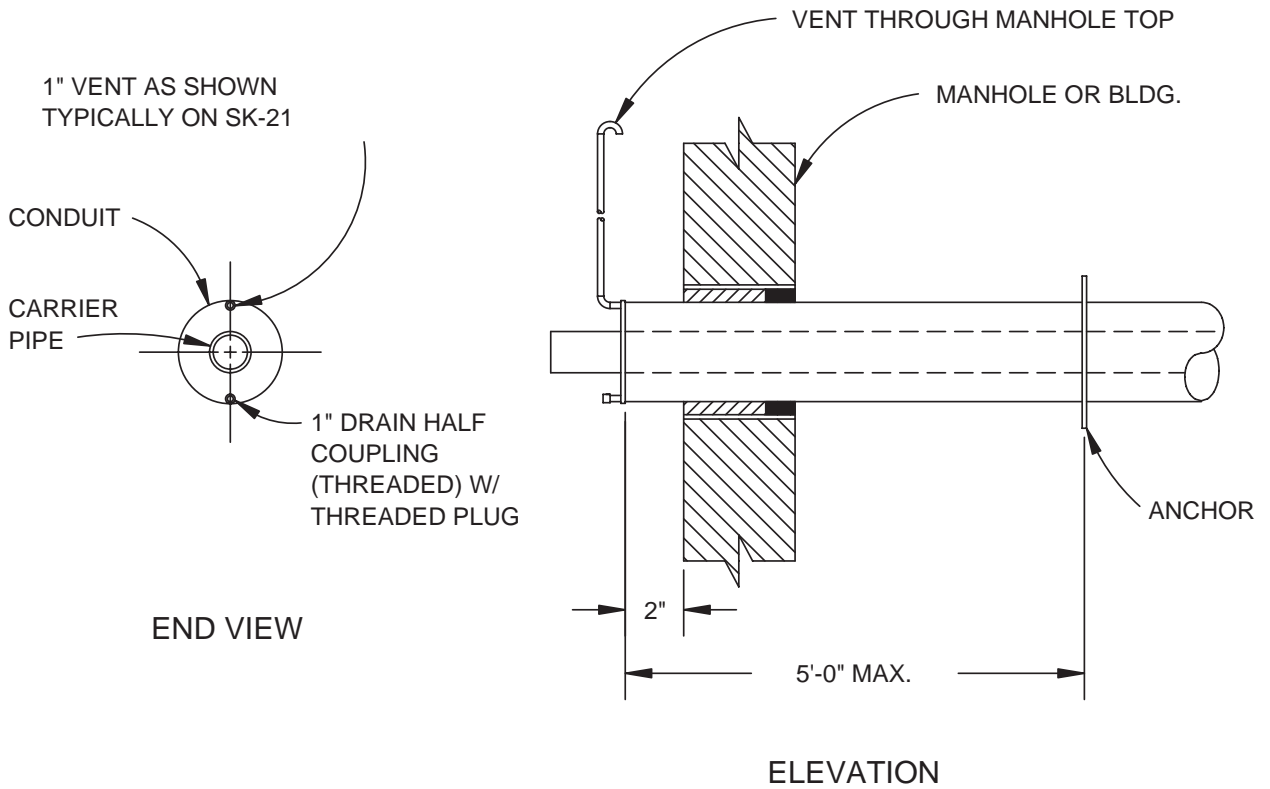

NOTE: USED WHEN ANCHOR IS WITHIN 5' OF A MANHOLE OR BUILDING WALL.