



HT-406 Details

HTAD
2.301

RISER DETAIL

3.26.09

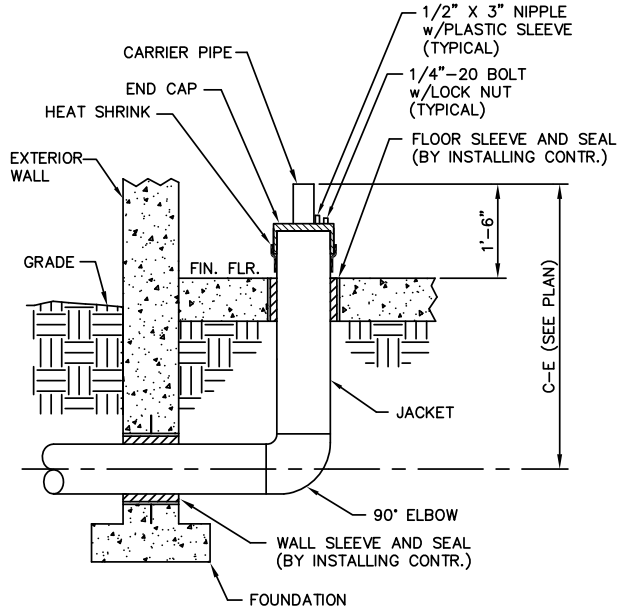

ELEVATION

BUILDING RISER DETAIL

SCALE: NONE

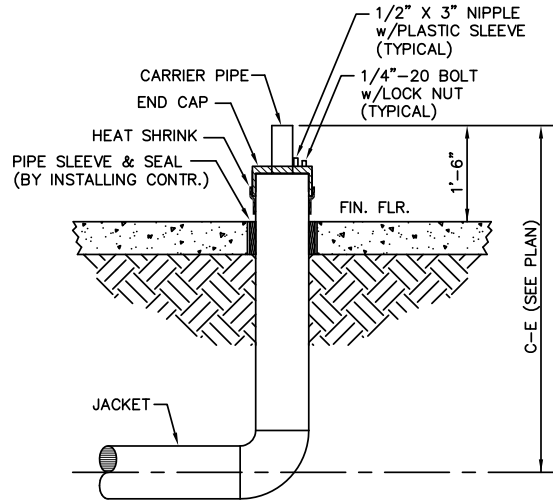

ELEVATION

PIPING RISER DETAIL

SCALE: NONE

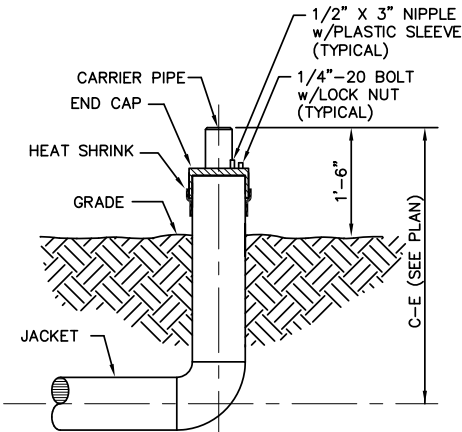

ELEVATION

RISER DETAIL

SCALE: NONE

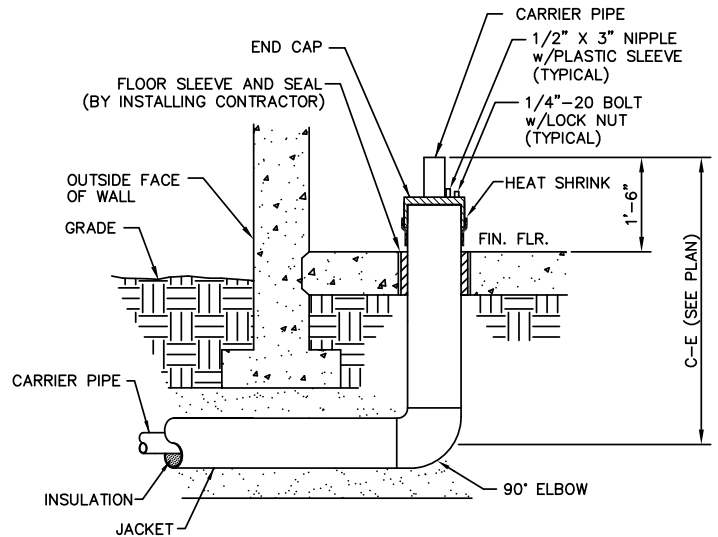

ELEVATION

BUILDING RISER DETAIL

SCALE: NONE

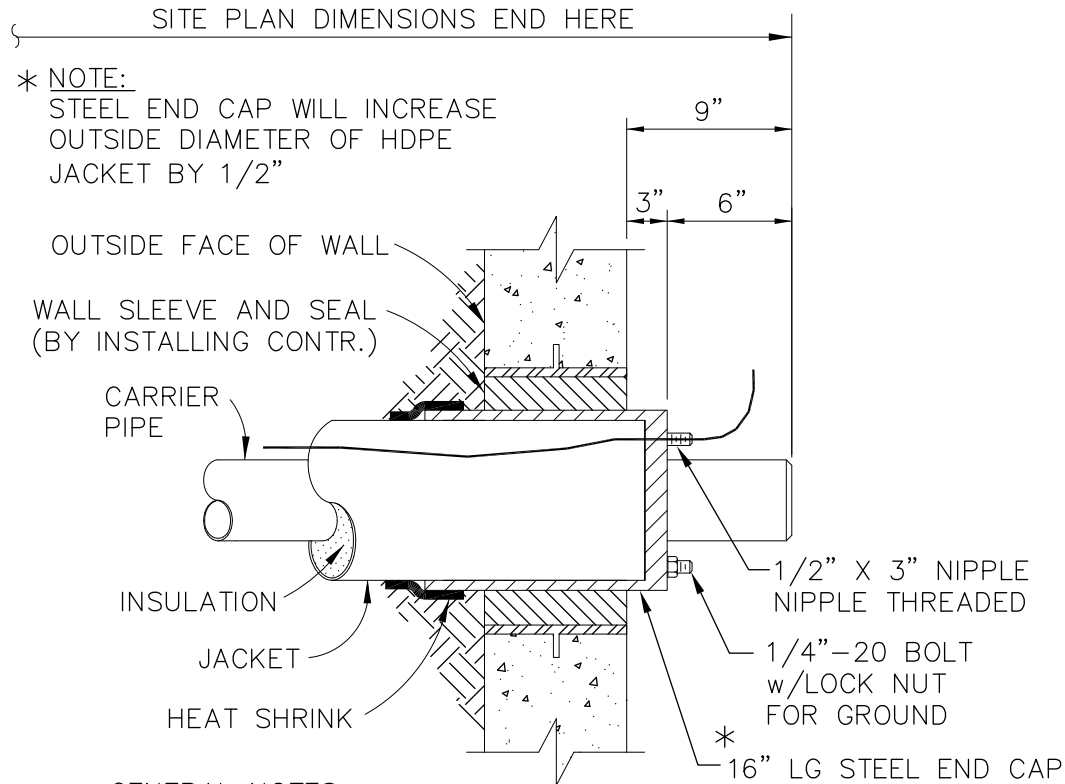

GENERAL NOTES:

- (1) FOR SYSTEMS WHICH ARE ANCHORED, A LINK-SEAL ASSEMBLY CAN BE UTILIZED FOR WATERPROOFING THE WALL PENETRATION.
- (2) IF EXPANSION THRU THE WALL IS ANTICIPATED, WE RECOMMEND THE FOLLOWING SEALING MECHANISM:
 - A. WRAP THE EXTERIOR OF THE JACKET WITH AN OILED OAKUM MATERIAL FROM THE INSIDE OF THE WALL TO ABOUT HALFWAY THRU THE WALL.
 - B. WRAP THE EXTERIOR OF THE JACKET WITH ARMAFLEX MATERIAL TO THE OUTER WALL.
 - C. COAT THE ARMAFLEX WITH A BITUMASTIC SEALANT.

WALL PENETRATION DETAIL

SCALE: NONE

INSTALLATION INSTRUCTIONS:

EXPANSION BOLSTERS PROCEDURE

1. EXPANSION BOLSTER MATERIAL IS SUPPLIED IN PADS:
6'-0" LONG x 3" THICK x HEIGHT SPECIFIED ON CHART.
4'-0" LONG x 1" THICK x HEIGHT SPECIFIED ON CHART.
2. PLACE BOLSTER PADS AGAINST JACKET AND CURVE AROUND ELBOW AS SHOWN. HOLD IN PLACE BY ATTACHING PADS TO JACKET WITH DUCT TAPE OR EQUIVALENT ON TOP AND BEDDING SAND ON THE BOTTOM. BE CERTAIN THAT THE BOLSTER PADS FITS SNUG TO JACKET.
3. BOLSTER PAD CONFIGURATION IS DEPENDENT ON LAYOUT & WILL BE SHOWN ON THE INSTALLATION DRAWING.

HDPE JACKET OD (INCHES)	PAD HEIGHT (INCHES)
5.40	7
6.68	7
8.68	7
10.85	13
12.85	13
14.1	13
16.1	17
18.2	17
20.28	17
22.2	25
24.38	25
28.25	25

SCALE: NONE

*** NOTE:**

DUCT TAPE TO BE 1'-0" ON CENTERS.

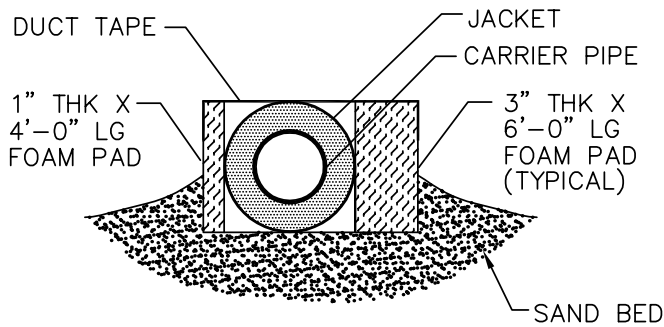

CROSS SECTION

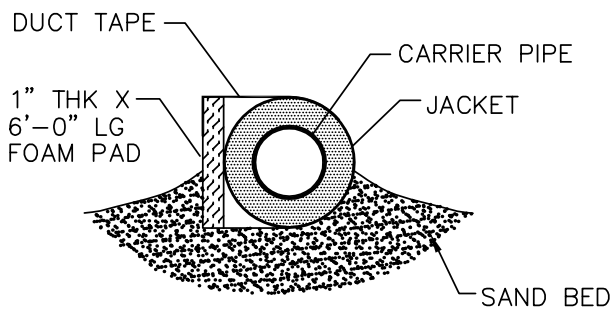
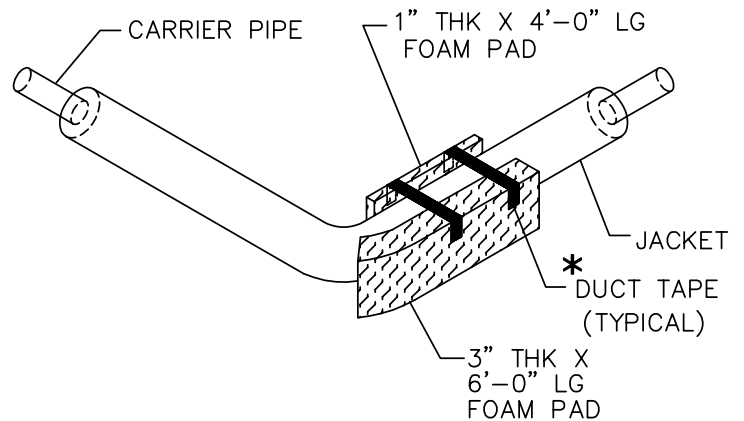

CROSS SECTION

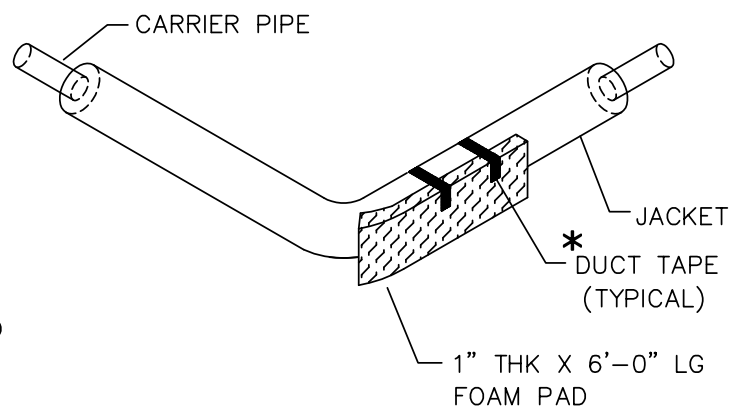

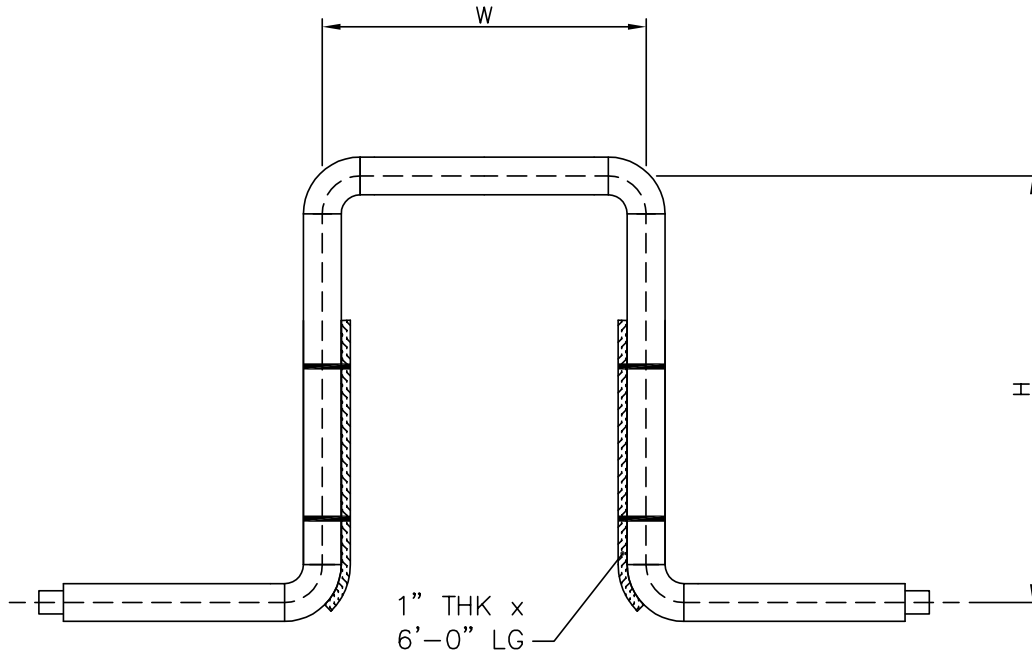

(1- PAD VIEW)

HT-406 EXPANSION LOOP DETAIL
SCALE: NONE

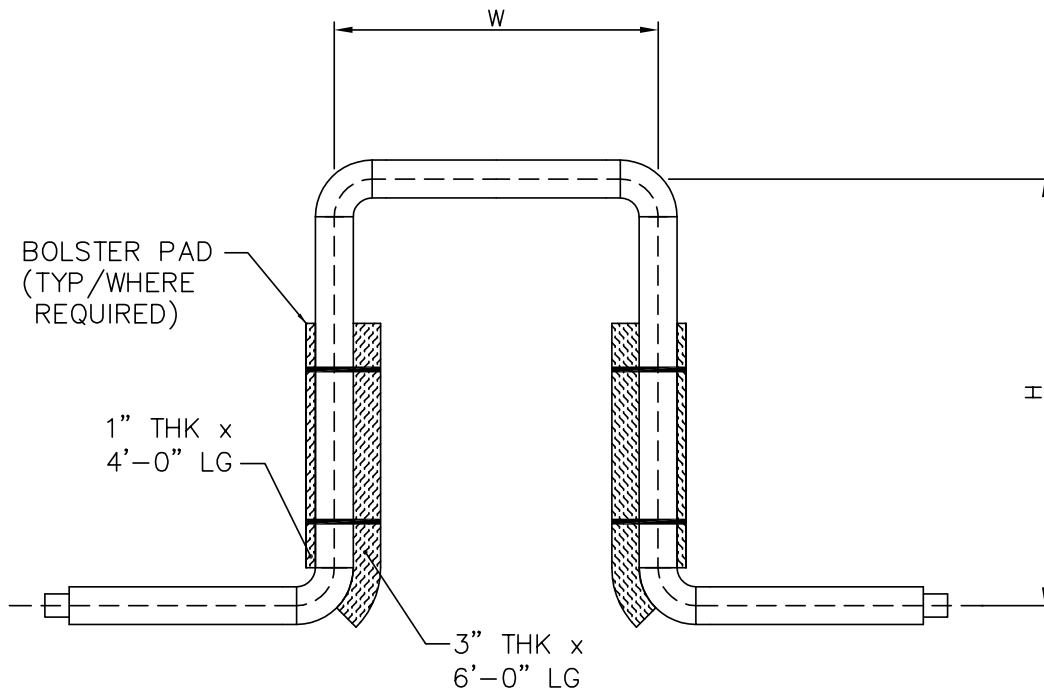

(2- PAD VIEW)

HT-406 EXPANSION LOOP DETAIL
SCALE: NONE

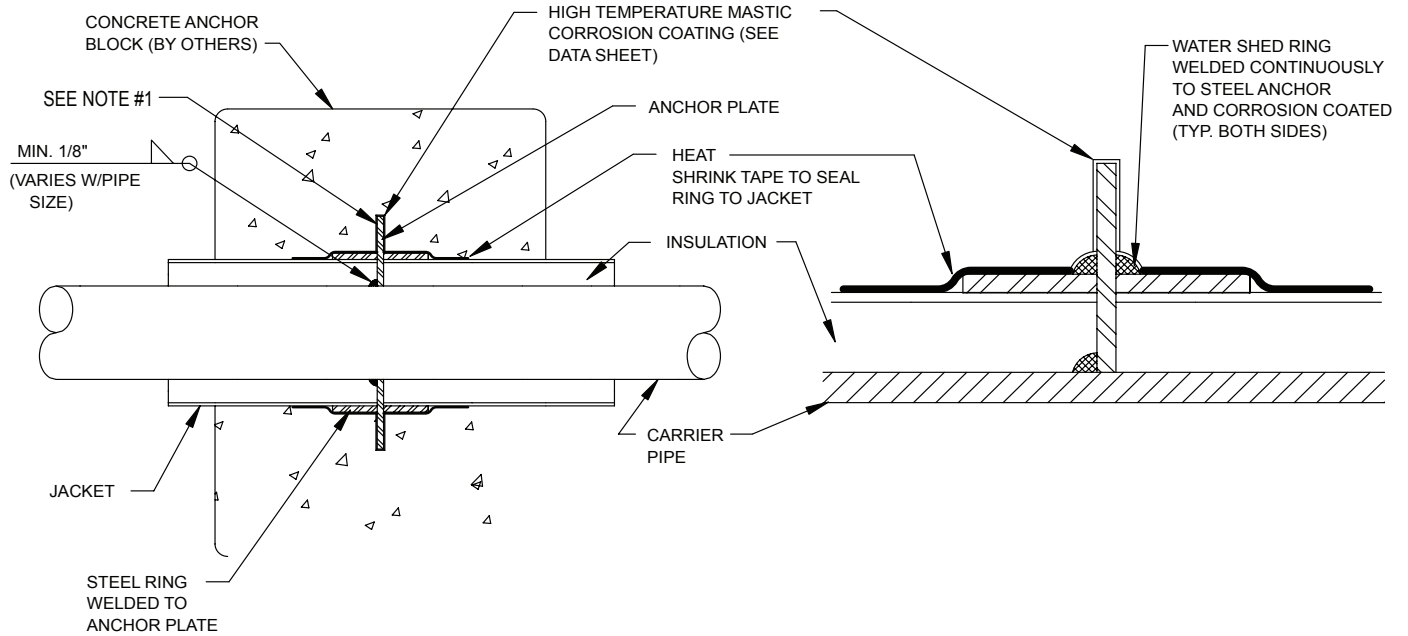

STEEL PIPE ANCHOR SPECIFICATIONS

1. STEEL ANCHOR PLATE AND WELDED RINGS FURNISHED BY THERMACOR. ANCHOR PLATE SHALL MEET ASTM A36 AND ON ALL SIZES SHALL BE 1/2" THICK. ANCHOR PLATE SHALL EXTEND 2-1/2" BEYOND THE CASING DIAMETER ON ALL SIDES. ANCHOR PLATE SHALL BE CORROSION COATED WITH A HIGH TEMPERATURE MASTIC MATERIAL AFTER WATERSHED RINGS HAVE BEEN SEALED TO CASING BY HEAT SHRINK TAPE.
2. ANCHOR ASSEMBLY SHALL BE POURED IN A CONCRETE BLOCK BY THE CONTRACTOR IN THE FIELD. GENERALLY, THE ANCHOR BLOCK EXTENDS 12" IN ALL DIRECTIONS FROM THE ANCHOR AND RESTS ON UNDISTURBED EARTH. THE JOB SITE CONDITIONS SHALL BE THE FINAL DETERMINING FACTOR FOR ANCHOR BLOCK SIZING.

PIPING ANCHOR DETAIL

SCALE: NONE

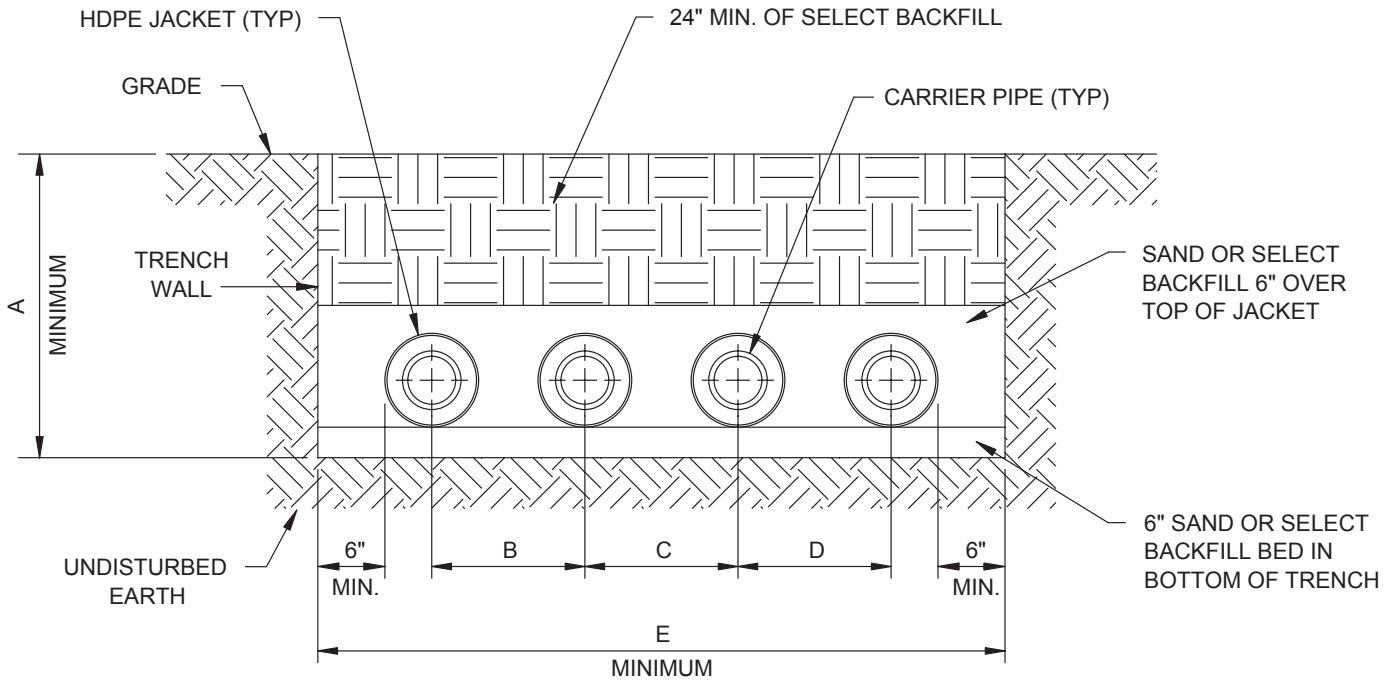

4-PIPE TRENCH SECTION

SCALE: NONE