



# DUO-THERM "505"

## Specification Guide

DTSG  
3.101

STANDARD SPECIFICATION

7.01.08

*Duo - Therm "505" Steel Piping Systems suitable for Steam, High Temperature Hot Water, Gravity and Pumped Condensate.*

### Part 1 - General

**1.1 Pre-insulated Piping** - Furnish a complete system of factory pre-insulated steel piping for the specified service. The system shall be a combination of a drainable, dryable, testable type conduit system, suitable for all ground water and soil conditions, site Classification "A" (Federal Construction Guide Spec. 02695), with an external covering of polyurethane insulation and an HDPE jacket. The system shall be provided as specified below and shown on the drawings.

**1.2 The pre-insulated pipe manufacturer shall make a complete layout of the system** showing anchors, expansion provisions, and building entrance details. Means for expansion must be made in pipe offsets or loops unless this is compensated for integrally in the system.

**1.3 The system shall be Duo-Therm "505"** as manufactured by **Thermacor Process, L.P.**, of Fort Worth, Texas.

### Part 2 - Products

**2.1 The conduit** shall be 10 gauge, welded, smooth-wall black steel conforming to ASTM A-139, A-134, and A-135. Conduit shall be tested at the factory to insure air and watertight welds prior to any fabrication or application of coating. No internal coating of conduit

**2.2 Conduit closures** shall be 10 gauge steel, furnished with the conduit at a ratio of one closure for each fabricated item or length. Closures shall be field welded over adjacent units after pipe insulation.

**2.3 Piping in the conduit** shall be standard weight (Std. Wt. is the same as Sch. 40 through 10"), steel, ASTM A-53, Grade B, ERW 2" and larger and A-106 SWI for 1- 1/2" and smaller. Steam lines shall be standard weight, and condensate lines shall be extra strong (XS is the same as Sch. 80 through 8"). Pipe joints shall be welded in accordance with the Pressure Piping Code, ASME/ANSI B 31.1.

**2.4 The Class "A" pipe insulation** shall be mineral wool applied to the thickness shown on drawing DTSG 3.105.

**2.5 Pre-fabricated ells, loops, and tees** shall be furnished and installed where shown on plans and shall consist of pipe, insulation, and conduit conforming to the same specification as hereinbefore stated for straight runs. Expansion loops shall be designed in accordance with the stress limits as dictated by the Power Piping Code, ASME/ANSI B31.1. Loop piping shall be installed in conduit suitably sized to handle indicated pipe movement. Elbows, loops, offsets, or any other direction changes shall conform to the standards set by ASME B31.1, Code for Power Piping.

**2.6 Terminal ends of conduits** inside manholes, pits, or building walls shall be equipped with end seals consisting of a 1/2" steel plate welded to the pipe and conduit, followed by the 16" steel sleeve, and with a 2" overlap of the heat shrink sleeve. End seals shall be equipped with drain and vent openings. Terminate all conduits 2" beyond the inside face of manhole or building walls.

**2.7 Pre-fabricated anchors** shall be furnished and installed where shown on plans and shall consist of a steel plate, welded to pipe and conduit. The steel anchor plate shall be 1/2" thick and shall be 1-1/2" larger horizontally and 1-1/2" larger vertically than the HDPE jacket outer diameter. Heat shrink wrap shall be used seal the overlap of anchor water shed over the HDPE jacket.

**2.8 A concrete thrust block** shall be cast over the anchor plate and conduit, large enough for firm anchorage into undisturbed trench sidewalls and/ or bottom. The concrete block shall be at least 36" in length and extend a minimum of 12" beyond the top and bottom of the anchor plate.

**2.9 Wall sleeves with leak plates** shall be provided at all building and manhole entries to provide an effective moisture barrier. The space between the conduit and wall sleeve shall be made watertight by use of Link-Seal® pipe penetration seals or equal assemblies, which will also provide electrical isolation.

(Continued)



# DUO-THERM "505"

## Specification Guide

DTSG

3.102

STANDARD SPECIFICATION

3.04.08

**2.10 The steel conduit for the steam and condensate** shall be insulated with polyurethane foam insulation to a minimum thickness of 1". Insulation shall be rigid, minimum 90% closed cell polyurethane with a minimum 2.0 lbs per cubic foot density, compressive strength of 30 psi @ 75°F, and a coefficient of thermal conductivity (K factor) not higher than .15 @ 75°F per ASTM C518. Maximum conduit interface temperature shall not exceed 200°F.

**2.11 Jacketing material** shall be extruded, black, high density polyethylene (HDPE), having a minimum wall thickness of 125 mils for jacket sizes less than or equal to 12", 150 mils for jacket sizes larger than 12" to 20", and 175 mils for jacket sizes greater than 20". The inner surface of the HDPE jacket shall be oxidized by means of corona treatment, flame treatment (patent pending), or other approved methods. This will ensure a secure bond between the jacket and foam insulation preventing any ingress of water at the jacket/ foam interface.

**2.12 Straight run joints** are insulated using a wrap around HDPE jacket placed over the field joint and insulated with polyurethane foam. The HDPE jacket is sealed with a heat shrink sleeve, as recommended by the manufacturer.

**2.13 Conduit fittings** are factory pre-fabricated and pre-insulated with urethane to the thickness specified and jacketed with a molded, extrusion welded, or butt fusion welded PE jacket. **NO TAPING OR HOT AIR WELDING SHALL BE ALLOWED.**

### Part 3 - Execution

**3.1 The installing contractor** shall be responsible to excavate, string conduit, weld test, place in trench, backfill, or otherwise treat and install the system as per the specifications and the directions furnished by the manufacturer and approved by the design engineer in accordance with plans and specifications.

**3.2 The conduit shall be air tested** at 15 psi. Test pressure shall be held for two hours. Repair any conduit leaks and retest prior to making joint closures.

**3.3 Pre-engineered systems** shall be provided with all straight pipe and fittings factory pre-insulated and pre-fabricated to job dimensions.

**3.4 Underground systems** shall be buried in a trench not less than two feet deeper than the top of the pipe and not less than eighteen inches wider than the combined O.D. of all piping systems. A minimum thickness of 24 inches of compacted backfill placed over the top of the pipe will meet H-20 highway loading.

**3.5 Trench bottom** shall have a minimum of 6" of sand, pea gravel, or specified backfill as a cushion for the piping. All field cutting of the pipe shall be performed in accordance with the manufacturer's installation instructions.

**3.6 A hydrostatic pressure test** of the carrier pipe shall be performed per the engineer's specification with a factory recommendation of one and one-half times the normal system operating pressure for not less than two hours. Care shall be taken to insure all trapped air is removed from the system prior to the test. *Appropriate safety precautions shall be taken to guard against possible injury to personnel in the event of a failure.*



# DUO-THERM "505"

## Specification Guide

DTSG  
3.103

PRESSURE TESTABLE SPECIFICATION WITH ERM

7.01.08

*Duo - Therm "505" Steel Piping Systems suitable for Steam, High Temperature Hot Water, and Gravity or Pumped Condensate.*

### Part 1 - General

**1.1 Pre-insulated Piping** - Furnish a complete system of factory pre-insulated steel piping for the specified service. The system shall be a combination of a drainable, dryable, testable type conduit system, suitable for all ground water and soil conditions, site Classification "A" (Federal Construction Guide Spec. 02695), with an external covering of polyurethane insulation and an HDPE jacket. The jacket throughout the entire system shall incorporate electric fusion, butt fusion, or extrusion welding at all fittings, joint closures, or other points of connection. This shall create a jacket that is seamless throughout the entire system with the exception of anchors, whose water shed rings are sealed with a Raychem Dirax or Canusa GTS-65 wrap prohibiting the ingress of water. All pre-insulated pipe, fittings, insulating materials, and technical support shall be provided by the Pre-insulated Piping System manufacturer. The system shall be provided as specified below and shown on the drawings.

**1.2 The pre-insulated pipe manufacturer shall make a complete layout of the system** showing anchors, expansion provisions, and building entrance details. Means for expansion must be made in pipe offsets or loops unless this is compensated for integrally in the system.

**1.3 The system shall be Duo-Therm "505"** as manufactured by **Thermacor Process, L.P.**, of Fort Worth, Texas.

### Part 2 - Products

**2.1 The conduit** shall be 10 gauge, welded, smooth-wall black steel conforming to ASTM A-139, A-134, and A-135. Conduit shall be tested at the factory to insure air and watertight welds prior to any fabrication or application of coating. No internal coating of conduit.

**2.2 Conduit closures** shall be 10 gauge steel, furnished with the conduit at a ratio of one closure for each fabricated item or length. Closures shall be field welded over adjacent units after pipe insulation.

**2.3 Piping in the conduit** shall be standard weight (Std. Wt. is the same as Sch. 40 through 10"), steel, ASTM A-53, Grade B, ERW 2" and larger, and A106 SML. Steam lines shall be standard weight and condensate lines shall be extra strong, (XS is the same as Sch. 80 through 8"). Pipe joints shall be welded in accordance with the Pressure Piping Code, ASME/ANSI B 31.1.

**2.4 The Class "A" pipe insulation** shall be mineral wool applied to the thickness shown on drawing DTSG 3.105.

**2.5 Pre-fabricated ells, loops, and tees** shall be furnished and installed where shown on plans and shall consist of pipe, insulation, and conduit conforming to the same specification as hereinbefore stated for straight runs. Expansion loops shall be designed in accordance with the stress limits as dictated by the Power Piping Code, ASME/ANSI B31.1. Loop piping shall be installed in conduit suitably sized to handle indicated pipe movement.

**2.6 Terminal ends of conduits** inside manholes, pits, or building walls shall be equipped with end seals consisting of a 1/2" steel plate welded to the pipe and conduit, followed by the 16" steel sleeve, and with a 2" overlap of the heat shrink sleeve. End seals shall be equipped with drain and vent openings. Terminate all conduits 2" beyond the inside face of manhole or building walls.

**2.7 Pre-fabricated anchors** shall be furnished and installed where shown on plans and shall consist of a steel plate, welded to pipe and conduit. The steel anchor plate shall be 1/2" thick and shall be 1-1/2" larger horizontally and 1-1/2" larger vertically than the HDPE jacket outer diameter. Raychem Dirax or Canusa GTS-65 wrap shall be used to seal the overlap of the anchor water shed ring over the HDPE jacket.

**2.8 A concrete thrust block** shall be cast over the anchor plate and conduit, large enough for firm anchorage into undisturbed trench sidewalls and/or bottom. The concrete block shall be at least 36" in length and extend a minimum of 12" beyond the top and bottom of the anchor plate.

**2.9 Wall sleeves with leak plates** shall be provided at all building and manhole entries to provide an effective moisture barrier. The wall sleeve and leak plate shall be electrically isolated from building rebar. The space between the conduit and wall sleeve shall be made watertight by use of Link-Seal® pipe penetration seals or equal assemblies, which will also provide electrical isolation.

(Continued)



# DUO-THERM "505"

## Specification Guide

DTSG  
3.104

PRESSURE TESTABLE SPECIFICATION WITH ERM

3.04.08

**2.10 The steel conduit for the steam and condensate** shall be insulated with polyurethane foam insulation to a minimum thickness of 1". Insulation shall be rigid, minimum 90% closed cell polyurethane with a minimum 2.0 lbs per cubic foot density, compressive strength of 30 psi @ 75°F, and a coefficient of thermal conductivity (K factor) not higher than .15 @ 75°F per ASTM C518. Maximum conduit interface temperature shall not exceed 200°F.

**2.11 Jacketing material** shall be extruded, black, high density polyethylene (HDPE), having a minimum wall thickness of 125 mils for jacket sizes less than or equal to 12", 150 mils for jacket sizes larger than 12" to 20", and 175 mils for jacket sizes greater than 20". The jacket throughout the entire system shall incorporate electric fusion, butt fusion, or extrusion welding at all fittings, joint closures, or other points of connection. This shall create a jacket that is seamless throughout the entire system with the exception of anchors, whose water shed rings are sealed with a Raychem Dirax or Canusa GTS-65 wrap prohibiting the ingress of water. The inner surface of the HDPE jacket shall be oxidized by means of corona treatment, flame treatment (patent pending), or other approved methods. This will ensure a secure bond between the jacket and foam insulation preventing any ingress of water at the jacket/foam interface.

**2.12 Straight run joints** are jacketed with a pressure testable joint closure, either an electro-fusion welded split sleeve HDPE joint closure, Canusa Supercase, or Raychem Rayjoint. The joint shall be pressure tested at 5 psi for 5 minutes while simultaneously soap tested at the joint closure's seams for possible leaks. After passing the pressure test, joints are insulated using polyurethane foam and a closure patch is welded (as per specified joint closure instructions) over the foam holes. All joint closures and insulation shall occur at straight sections of pipe.

**2.13 Conduit fittings** are factory pre-fabricated and pre-insulated with urethane to the thickness specified and jacketed with a molded, extrusion welded, or butt fusion welded PE jacket. **NO TAPING OR HOT AIR WELDING SHALL BE ALLOWED.** All fitting jackets/covers shall be connected to the straight lengths of pipe by electro fusion, butt fusion, or extrusion welding.

**2.14 The system shall be leak detection ready** by means of manufacturing into the system a copper wire through each piece of pre-insulated pipe and fittings. The piping system manufacturer shall install the wire in a manner that has the wire embedded in the outer polyurethane foam insulation and not touching the steel conduit. The contractor shall connect the wire together at each field joint with a recommended crimping tool. After crimping the wire at the joint, the contractor shall check the joined pieces for continuity of the wire and electrical isolation from the conduit by use of a standard analog volt ohmmeter. This check shall be repeated after each crimp, until the entire system is connected. After the piping system is installed, the owner at any time may check the system for a conduit leak by using a standard volt ohmmeter. If a leak is detected (a leak is signaled by a drastic drop in the electrical resistance of the circuit) the owner should contact the system manufacturer for a TDR instrument to determine the location of the leak. (At owner's option, an ohmmeter panel may be purchased which will provide continuous leak detection monitoring.)

### **Part 3 - Execution**

**3.1 The installing contractor** shall be responsible to excavate, string conduit, weld test, place in trench, backfill, or otherwise treat and install the system as per the specifications and the directions furnished by the manufacturer and approved by the design engineer in accordance with plans and specifications.

**3.2 The conduit shall be air tested** at 15 psi. Test pressure shall be held for two hours. Repair any conduit leaks and retest prior to making joint closures.

**3.3 Pre-engineered systems** shall be provided with all straight pipe and fittings factory pre-insulated and pre-fabricated to job dimensions.

**3.4 Underground systems** shall be buried in a trench not less than two feet deeper than the top of the pipe and not less than eighteen inches wider than the combined O.D. of all piping systems. A minimum thickness of 24 inches of compacted backfill placed over the top of the pipe will meet H-20 highway loading.

**3.5 Trench bottom** shall have a minimum of 6" of sand, pea gravel, or specified backfill as a cushion for the piping. All field cutting of the pipe shall be performed in accordance with the manufacturer's installation instructions.

**3.6 A hydrostatic pressure test** of the carrier pipe shall be performed per the engineer's specification with a factory recommendation of one and one-half times the normal system operating pressure for not less than two hours. Care shall be taken to insure all trapped air is removed from the system prior to the test. *Appropriate safety precautions shall be taken to guard against possible injury to personnel in the event of a failure.*



# DUO-THERM "505"

## Specification Guide

DTSG  
3.105

DUO-THERM IN HDPE JACKET

3.04.08

**Carrier Pipe:**

- $d \geq 2"$  - A53 ERW Grade B, Std. Wt. Black Steel
- Seamless and Schedule 80 pipe available for all sizes
- Std. Wt. is the same as Schedule 40 for all sizes thru 10"
- XS is the same as Schedule 80 for all sizes thru 8"

**Conduit:**

- $6" \leq c \leq 26"$  - 10 Gauge
- $28" \leq c \leq 36"$  - 6 Gauge
- $38" \leq c \leq 42"$  - 4 Gauge

**Jacketing Material:**

High Density Polyethylene (HDPE)

**Insulation:**

- Mineral Wool
- Polyurethane Foam

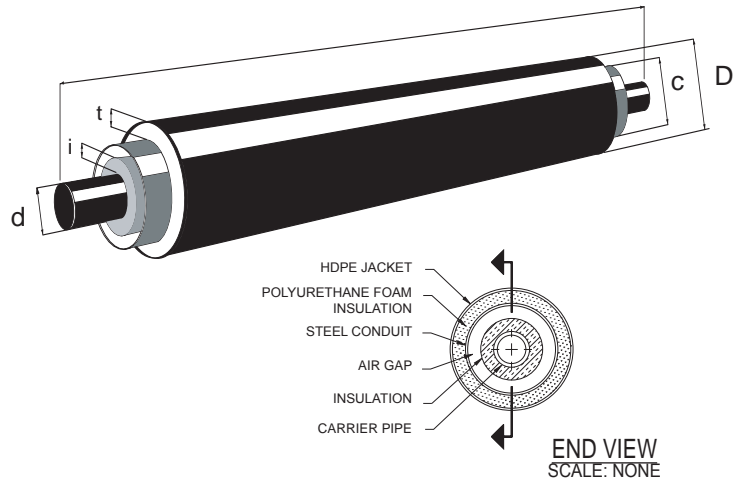

Pipe Size	Mineral Wool Thickness i	Conduit O.D. c	Min. Insulation Thickness t	External Diameter D
2"	1-1/2"	8-5/8"	1.0"	10.9"
3"	1-1/2"	8-5/8"	1.0"	10.9"
4"	1-1/2"	10-3/4"	1.0"	13.1"
6"	2"	12-3/4"	1.0"	15.1"
8"	2"	16"	1.0"	18.3"
10"	2"	18"	1.0"	20.3"
12"	2-1/2"	20"	1.0"	22.3"
14"	2-1/2"	22"	1.0"	24.4"
16"	3"	24"	1.0"	26.4"
18"	3"	26"	1.0"	28.4"
20"	3"	28"	1.0"	30.4"
24"	3-1/2"	34"	1.0"	36.4"

\* Other pipe sizes and pipe, insulation thickness, and conduit size combinations are available.

\*\* Insulation thickness is calculated using minimum wall thickness. Actual wall thickness may be greater than stated, thereby minimally increasing actual external diameter.

### HEAT LOSS FOR STANDARD SIZES OF MINERAL WOOL AND 1" POLYURETHANE FOAM\*

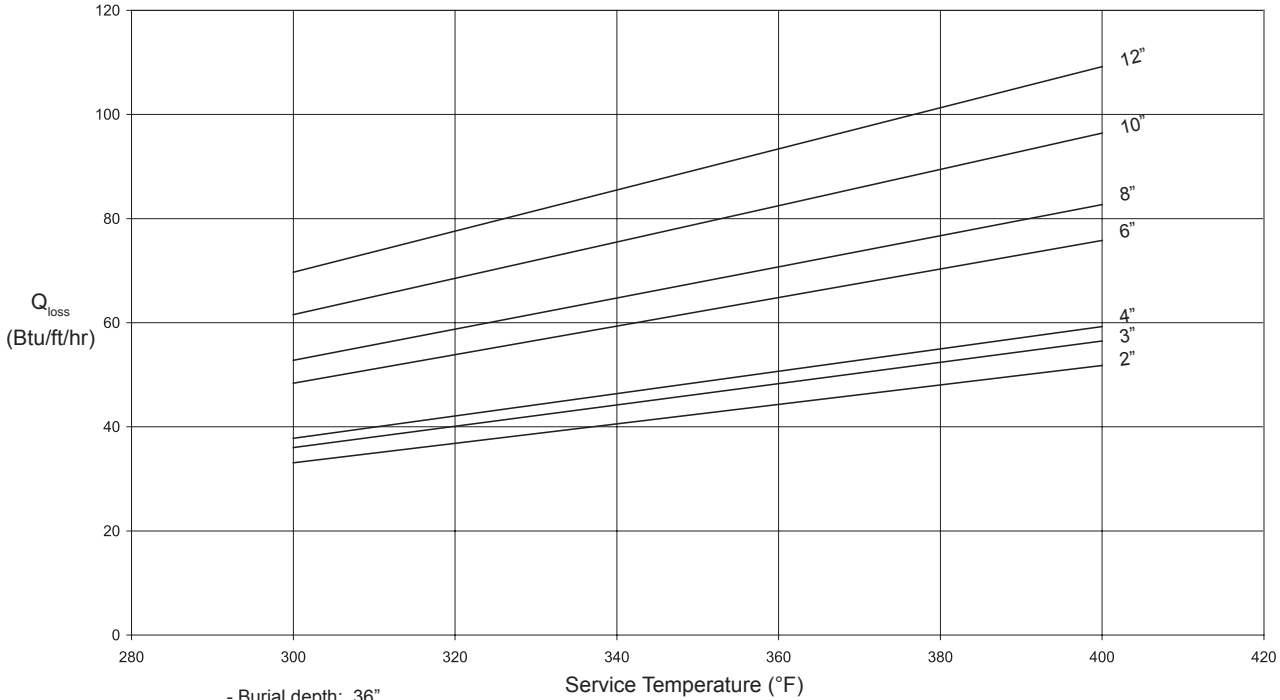

- Burial depth: 36"
- Soil conductivity: 12 (Btu/h.ft<sup>2</sup>.°F/ft)
- Soil temperature: 50°F

Pipe Size	Mineral Wool Thickness	Conduit O.D.	Polyurethane Thickness
2"	1-1/2"	8-5/8"	1.0"
3"	1-1/2"	8-5/8"	1.0"
4"	1-1/2"	10-3/4"	1.0"
6"	2"	12-3/4"	1.0"
8"	2"	16"	1.0"
10"	2"	18"	1.0"
12"	2-1/2"	20"	1.0"
14"	2-1/2"	22"	1.0"
16"	3"	24"	1.0"
18"	3"	26"	1.0"
20"	3"	28"	1.0"
24"	3-1/2"	34"	1.0"

\* Other pipe sizes and pipe, insulation thickness, and conduit size combinations are available.