



COPPER-THERM O-RING

Specification Guide

COSG
6.301

STANDARD SPECIFICATION

3.14.07

Pre-insulated Copper O-Ring Piping Systems suitable for Heating Water, Domestic Hot Water, Chilled Water, Condensate Return, Process Fluids, and Cryogenic services.

Part 1 – General

1.1 Pre-insulated Piping - Furnish a complete system of factory pre-insulated copper piping for the specified service. All pre-insulated pipe, fittings, insulating materials, and technical support shall be provided by the Pre-insulated Piping System manufacturer.

1.2 The system shall be **COPPER-THERM O-Ring** manufactured by **Thermacor Process, L.P.**, of Fort Worth, Texas.

Part 2 – Products

2.1 Carrier pipe shall be Type K Copper tube, conforming to ASTM B-88. (*At the Engineer's option*, Type L or Type M is acceptable). All copper piping shall have ends cut square for socket brazing. Straight sections of factory insulated pipe shall be 20-foot in length and shall have 2" of exposed pipe at each end for field joint assembly, or 6" for brazed connection.

2.2 Insulation shall be polyurethane foam either spray applied or injected with one shot into the annular space between carrier pipe and jacket. Insulation shall be rigid, 90% minimum closed cell polyurethane with a minimum 2.0 lbs per cubic foot density, compressive strength of 30 psi @ 75°F, and coefficient of thermal conductivity (K-Factor) of not higher than 0.15 @ 75°F per ASTM C-518. Maximum operating temperature shall not exceed 250°F. Insulation thickness shall be specified by calling out appropriate carrier pipe and jacket size combinations as listed on drawing CUSG 6.303 or 6.304.

2.3 Jacketing material shall be either extruded white polyvinyl chloride, consisting of clean, virgin NSF approved Class 12454-B PVC compound, conforming to ASTM D-1784, Type 1, Grade 1 or high density polyethylene (HDPE). PVC jacket shall have a wall thickness in mils equal to ten times the nominal jacket diameter and shall not be less than 60 mils. HDPE shall have a minimum wall thickness of 135 mils for jacket sizes less than or equal to 12" or 165 mils for jacket sizes larger than 12" and shall be used for all jacketing larger than 16". No FRP, HDUP, or tape jacket allowed.

2.4 Straight run joints are not insulated to allow for expansion and contraction of the gasketed joint. At the Engineer's option, straight field joints may be jacketed with either an HDPE or PVC sleeve and sealed with pressure sensitive, polyethylene backed, rubberized bitumen adhesive tape, 30 mils thick or heat shrink wrap to prevent the ingress of moisture or debris.

2.5 Fittings shall be cast bronze or wrought copper. Carrier pipe fittings shall be silver soldered or brazed with alloys melting at or above 1100°F; 50-50 tin-lead solder is not acceptable. Fittings are not insulated and are poured in concrete thrust blocks at all changes on direction. Thrust block design and sizing is the responsibility of the design engineer.

2.6 Expansion/ contraction compensation will be accomplished utilizing O-ring couplings to join straight pipe sections. The couplings shall consist of a machined coupling housing two EPDM sealing rings, and at the Engineer's option, jacketed with either an HDPE or PVC sleeve and sealed with polyethylene backed, pressure sensitive bituminous rubber tape, 30 mils thick. Couplings are required for distances between fittings of five feet or greater.

(Continued)



COPPER-THERM O-RING

Specification Guide

COSG

6.302

STANDARD SPECIFICATION

3.14.07

Part 3 – Execution

3.1 Underground systems shall be buried in a trench of not less than two feet deeper than the top of the pipe and not less than eighteen inches wider than the combined O.D. of all piping systems. A minimum thickness of 24 inches of compacted backfill over the top of the pipe will meet H-20 highway loading.

3.2 Trench bottom shall have a minimum of 6" of sand, pea gravel, or specified backfill material, as approved by the engineer, as a cushion for the piping. All field cutting of the pipe shall be performed in accordance with the manufacturer's installation instructions.

3.3 A hydrostatic pressure test of the carrier pipe shall be performed per the engineer's specification with a factory recommendation of one and one-half times the normal system operating pressure for not less than two hours. Care shall be taken to insure all trapped air is removed from the system prior to the test. *Appropriate safety precautions shall be taken to guard against possible injury to personnel in the event of a failure.*

3.4 Field service, if required by project specifications, will be provided by a certified manufacturer's representative or company field service technician. The technician will be available at the job to check unloading, storing, and handling of pipe, joint installation, pressure testing, and backfilling techniques. This service will be added into the cost as part of the project technical services required by the pre-insulated pipe manufacturer.



COPPER-THERM O-RING

Specification Guide

COSG
6.303

POLYURETHANE FOAM IN PVC JACKET

3.14.07

Carrier Pipe:

- Type K, L, or M Hard Copper (ASTM B-88)
- $d \geq 3"$ - 9" Cut Back
- $d \leq 2"$ - 6" Cut Back

Jacketing Material:

Polyvinyl Chloride (PVC)

Insulation:

Polyurethane Foam

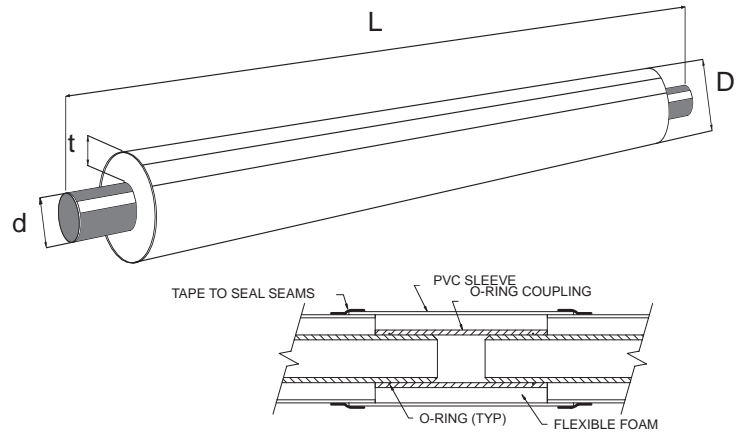

Pipe Size	Jacket Size	Standard Length L	Insulation Thickness t	External Diameter D
1/2"	3"	20'	1.38"	3.50"
	4"	20'	1.88"	4.50"
	6"	20'	2.69"	6.14"
3/4"	3"	20'	1.25"	3.50"
	4"	20'	1.75"	4.50"
	6"	20'	2.56"	6.14"
1"	3"	20'	1.13"	3.50"
	4"	20'	1.63"	4.50"
	6"	20'	2.44"	6.14"
1-1/4"	3"	20'	1.00"	3.50"
	4"	20'	1.50"	4.50"
	6"	20'	2.31"	6.14"
1-1/2"	4"	20'	1.38"	4.50"
	6"	20'	2.19"	6.14"
2"	4"	20'	1.13"	4.50"
	6"	20'	1.94"	6.14"
2-1/2"	6"	20'	1.69"	6.14"
	8"	20'	2.69"	8.16"
3"	6"	20'	1.44"	6.14"
	8"	20'	2.44"	8.16"
4"	6"	20'	.94"	6.14"
	8"	20'	1.94"	8.16"

* Other sizes are available



COPPER-THERM O-RING

Specification Guide

COSG

6.304

POLYURETHANE FOAM IN HDPE JACKET

3.14.07

Carrier Pipe:

- Type K, L, or M Hard Copper (ASTM B-88)
- $d \geq 3"$ - 9" Cut Back
- $d \leq 2"$ - 6" Cut Back

Jacketing Material:

High Density Polyethylene (HDPE)

Insulation:

Polyurethane Foam

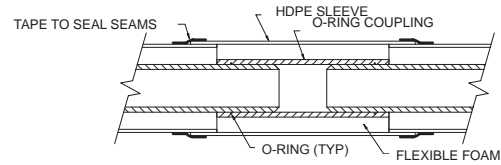
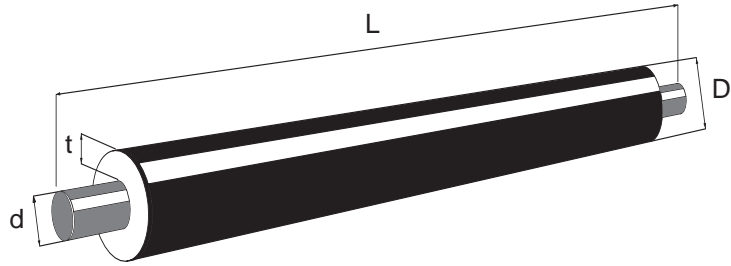

Pipe Size	Jacket Size	Standard Length L	Insulation Thickness t	External Diameter D	Minimum Jacket Thickness
1/2"	5.4"	20'	2.25"	5.40"	.135"
3/4"	5.4"	20'	2.13"	5.40"	.135"
1"	5.4"	20'	2.00"	5.40"	.135"
1-1/4"	5.4"	20'	1.88"	5.40"	.135"
	6.7"	20'	2.52"	6.68"	.135"
1-1/2"	5.4"	20'	1.75"	5.40"	.135"
	6.7"	20'	2.39"	6.68"	.135"
2"	5.4"	20'	1.50"	5.40"	.135"
	6.7"	20'	2.14"	6.68"	.135"
2-1/2"	5.4"	20'	1.25"	5.40"	.135"
	6.7"	20'	1.89"	6.68"	.135"
3"	5.4"	20'	1.00"	5.40"	.135"
	6.7"	20'	1.64"	6.68"	.135"
	8.7"	20'	2.64"	8.68"	.135"
4"	6.7"	20'	1.14"	6.68"	.135"
	8.7"	20'	2.14"	8.68"	.135"

* Other pipe and jacket combinations are available.

** Insulation thickness is calculated using minimum wall thickness. Actual wall thickness may be greater than stated, thereby minimally decreasing actual foam thickness.